

LCD Projector  
LVP-SA51U

## Control projector by using a personal computer

This projector can be controlled by connecting a personal computer with RS-232C terminal. Functions can be controlled by a personal computer:

- Turn the ON or OFF
- Changing input signals
- Menu setting

### Connection

#### Projector + IBM PC or IBM PC compatibles

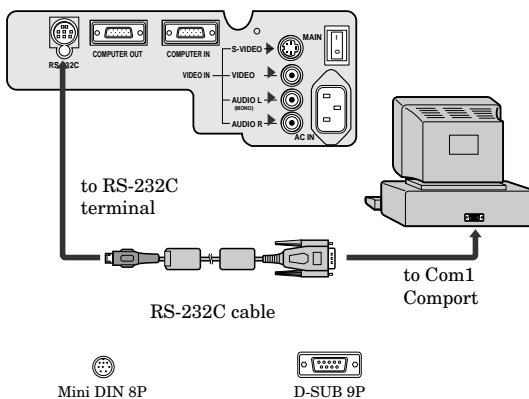

#### Projector + Macintosh

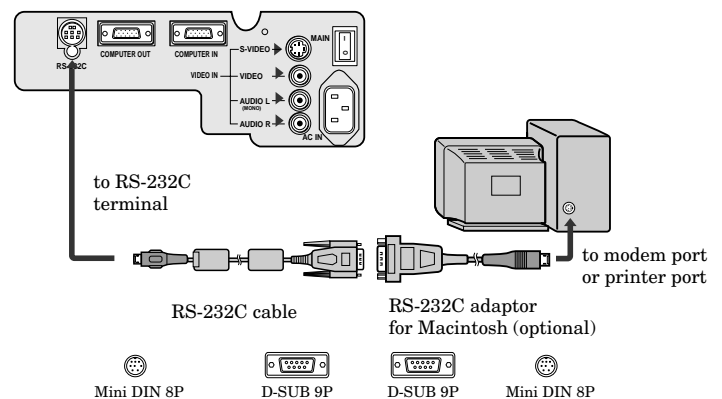

### Important:

- Make sure that your computer and projector are turned off before connection.
- Turn on the projector after the computer is started up.  
(If you do not follow this order, the Comport may not function.)
- If your PC (IBM or IBM compatible) is equipped only with a 25-pin serial port connector, a 25-pin serial port adaptor is required. Contact your dealer for details.

### 1) Interface

PROTOCOL	RS-232C
BAUD RATE	9600 [bps]
DATA LENGTH	8 [bits]
PARITY BIT	NONE
STOP BIT	1 [bit]
FLOW CONTROL	NONE

This projector uses RXD, TXD and GND lines for RS-232C control. For RS-232C cable, the reverse type cable should be used.

### 2) Control command diagram

The command is structured by the address code, function code, data code and end code. The length of the command is different by each function.

	Address code	Function code	Data code	End code
HEX	30h 30h	Function	Data	0Dh
ASCII	'0' '0'	Function	Data	↵

- [Address code] 30h 30h (In ASCII code, '0' '0') fixed.  
 [Function code] A code of each fixed control move.  
 [Data code] A code of each fixed control data (number) and not always indicated.  
 [End code] 0Dh (In ASCII code, '↵') fixed.

### 3) Control sequence

- (1) Send the command from a personal computer to the projector. (The commands must be sent at least 400ms apart.)
  - (2) The projector will send a return command 400ms\* after it has received an end code. If the command is not received correctly, the projector will not send the return command.
  - (3) The personal computer checks the command and confirms if the command which has been sent has been executed or not.
  - (4) This projector sends various codes other than the return code. When having a control sequence by RS-232C, reject other codes from personal computer side.
- \*: The sending time of return command may delay depending on the condition (during changing the input signal, etc.).

[Example] Turn the power ON (' is for ASCII code)

Sending commands from the PC etc.	Status code from projector	Meaning
30 30 21 0D '0' '0' '!' '␣'		Command for POWER ON
	30 30 21 0D '0' '0' '!' '␣'	Command received (Command echo back)

### 4) Operation commands

The operation commands execute the basic operation setting of this projector. It may not operate when changing the signal.

Operation	ASCII	HEX
POWER ON	!	21h
POWER OFF	"	22h
INPUT COMPUTER	_r1	5Fh 72h 31h
INPUT VIDEO	_v1	5Fh 76h 31h

- POWER OFF command will not work for 1 minute after the power is turned on.
- POWER ON command will not work for 1 minute after the power is turned off.

[Example] Set the input signal to COMPUTER (' is for ASCII code)

Sending commands from the PC etc.	Status code from projector	Meaning
30 30 5F 72 31 0D '0' '0' '_' 'r' '1' '␣'		Command for setting the input signal to COMPUTER
	30 30 5F 72 31 0D '0' '0' '_' 'r' '1' '␣'	Command received (Command echo back)

### 5) Volume commands

The volume commands execute the volume setting of this projector with the value.

ITEM	ASCII	HEX	VALUE
VOLUME	VL	56h 4Ch	00 - 60

#### How to set the grade

Use ASCII letters code to set the grade for setting data. Please refer to the table below for HEX code.

ASCII	'0'	'1'	'2'	'3'	'4'	'5'	'6'	'7'	'8'	'9'
HEX	30h	31h	32h	33h	34h	35h	36h	37h	38h	39h

[Example] Set the volume to 30 (Standard value) (' is for ASCII code)

Sending commands from the PC etc.	Status code from projector	Meaning
30 30 56 4C 33 30 0D '0' '0' 'V' 'L' '3' '0' '␣'		Command for setting the volume
	30 30 56 4C 33 30 0D '0' '0' 'V' 'L' '3' '0' '␣'	Command received (Command echo back)

## 6) Remote commands

Some remote control operations can be done by remote command codes.

Button's name on remote	ASCII	HEX
+ VOLUME	r06	72h 30h 36h
- VOLUME	r07	72h 30h 37h
EXPAND	r02	72h 30h 32h
MUTE	ra6	72h 61h 36h
▲	r53	72h 35h 33h
▼	r2b	72h 32h 62h
◀	r4f	72h 34h 66h
▶	r59	72h 35h 39h
MENU	r54	72h 35h 34h
ENTER	r10	72h 31h 30h
AUTO POSITION	r09	72h 30h 39h
STILL	ra4	72h 61h 34h

[Example] Display MENU selection bar. (' 'is for ASCII code)

Sending commands from the PC etc.	Status code from projector	Meaning
30 30 72 35 34 0D '0' '0' 'r' '5' '4' '↵'		Command as same as MENU button
	30 30 72 35 34 0D '0' '0' 'r' '5' '4' '↵'	Command received (Command echo back)

## 7) Reading command diagram

Monitor projector operation status. The power ON, OFF and input terminal settings can be monitored.

	ASCII		HEX	
	Function	Data (Receive)	Function	Data (Receive)
POWER ON	vP	1	76h 50h	31h
POWER OFF	vP	0	76h 50h	30h
INPUT COMPUTER	vI	r1	76h 49h	72h 31h
INPUT VIDEO	vI	v1	76h 49h	76h 31h

When a personal computer sends the command, data code will not be attached. On the other hand, the projector which has received a command will attach the recent operating status and then send.

[Example ] Input was Video when the operating status of the input terminal was confirmed.

Sending commands from the PC etc.	Status code from projector	Meaning
30 30 76 49 0D '0' '0' 'v' 'I' '↵'		Command to confirm input
	30 30 76 49 76 31 0D '0' '0' 'v' 'I' 'v' '1' '↵'	Command (Input is Video) carried out

## 8) Menu setting commands

The menu setting commands execute the menu setting of this projector. If the personal computer doesn't send the commands without attaching the data code, the projector which has received the command replays the setting data as data code.

ITEM	ASCII	HEX	VALUE
CONTRAST	P	50h	±30±30±30 (R from G+Main data+B from G)
BRIGHTNESS	Q	51h	±30±30±30 (R from G+Main data+B from G)
COLOR MATRIX (MODE)	CMT	43h 4Dh 54h	1, 2, 3, 4 (USER), 5 (OFF)
COLOR MATRIX (R, G, B)	MRGB	4Dh 52h 47h 42h	±30±30±30 (R+G+B)
COLOR MATRIX (Y, C, M)	MYCM	4Dh 59h 43h 4Dh	±30±30±30 (Y+C+M)
COLOR TEMP.	A	41h	1 (Standard), 2 (High), 3 (Low), 4 (User)
SHARPNESS	R	52h	±10
TINT	S	53h	±10
COLOR	T	54h	±10

ITEM	ASCII	HEX	VALUE
AUTO POWER ON	APON	41h 50h 4Fh 4Eh	<b>0</b> (OFF), <b>1</b> (ON)
AUTO POWER OFF	APOF	41h 50h 4Fh 46h	<b>00</b> (Off), <b>05, 10, 15, 30, 60</b>
IMAGE REVERSE	IR	49h 52h	<b>0</b> (OFF), <b>1</b> (Mirror), <b>2</b> (Invert), <b>3</b> (Mirror invert)
MENU POSITION	MP	4Dh 50h	<b>0</b> (Upper left), <b>1</b> (Lower right)
EXPAND MODE	EX	45h 58h	<b>1 - 2</b>
AUDIO MODE	AU	41h 55h	<b>1</b> (COMPUTER), <b>2</b> (VIDEO), <b>3</b> (COMPUTER & VIDEO)
VIDEO SIGNAL	VS	56h 53h	<b>0</b> (AUTO), <b>1</b> (NTSC), <b>2</b> (PAL), <b>3</b> (SECAM), <b>4</b> (4.43NTSC), <b>5</b> (PAL-M), <b>6</b> (PAL-N), <b>7</b> (PAL-60)
ANAMORPHIC	SC	53h 43h	<b>0</b> (OFF), <b>1</b> (ON)
LANGUAGE	LG	4Ch 47h	<b>0</b> (日本語), <b>1</b> (English), <b>2</b> (Español), <b>3</b> (Deutsch), <b>4</b> (Français), <b>5</b> (Italiano), <b>6</b> (中文)
RESET ALL	RSTALL	52h 53h 54h 41h 4Ch 4Ch	
MEMORY CALL	MMC	4Dh 4Dh 43h	<b>0</b> (AUTO), <b>1</b> (USER1), <b>2</b> (USER2)
HORIZ. POSITION	HP	48h 50h	<b>+</b> (increase), <b>-</b> (decrease)
VERT. POSITION	VP	56h 50h	<b>+</b> (increase), <b>-</b> (decrease)
FINE SYNC.	FN	46h 4Eh	<b>00 - 39</b>
TRACKING	TRK	54h 52h 4Bh	<b>+</b> (increase), <b>-</b> (decrease)
COMPUTER INPUT	CIN	67h 49h 4Eh	<b>0</b> (RGB), <b>1</b> (YCbCr/YPbPr)
HOLD	HLD	48h 4Ch 44h	<b>0</b> (AUTO), <b>1</b> (ON), <b>2</b> (OFF)
HOLD BEGIN	HLB	48h 4Ch 42h	<b>-01 - -99</b>
HOLD END	HLE	48h 4Ch 45h	<b>01 - 99</b>
CLAMP POSITION	CLP	43h 4Ch 50h	<b>00 - 63</b>
CLAMP WIDTH	CLW	43h 4Ch 57h	<b>01 - 63</b>
HORIZ. PIXELS	HPL	48h 50h 4Ch	<b>0000 - 9999</b>
VERT. LINES	VLN	56h 4Ch 4Eh	<b>0000 - 9999</b>
PLL	PLL	50h 4Ch 4Ch	<b>0</b> (AUTO), <b>1</b> (0), <b>2</b> (1), <b>3</b> (2), <b>4</b> (3), <b>5</b> (4), <b>6</b> (5), <b>7</b> (6), <b>8</b> (7)
VERT.SYNC	VSC	56h 53h 43h	<b>0</b> (AUTO), <b>1</b> (ON), <b>2</b> (OFF)
SHUTTER (U)	SHU	53h 48h 55h	<b>000 - 299</b>
SHUTTER (L)	SHL	53h 48h 4Ch	<b>000 - 299</b>
SHUTTER (LS)	SHLS	53h 48h 4Ch 53h	<b>000 - 398</b>
SHUTTER (RS)	SHRS	53h 48h 52h 53h	<b>000 - 398</b>

### How to set the grade

Use ASCII letters code to set the grade for setting data. Please refer to the table below for HEX code.

ASCII	'+'	'_'	'0'	'1'	'2'	'3'	'4'	'5'	'6'	'7'	'8'	'9'
HEX	2Bh	2Dh	30h	31h	32h	33h	34h	35h	36h	37h	38h	39h

[Example 1] Set the AUTO POWER ON to ON.

Sending commands from the PC etc.	Status code from projector	Meaning
30 30 41 50 4F 4E 30 0D '0' '0' 'A' 'P' 'O' 'N' '1' '␣'		Command for setting the AUTO POWER ON to ON
	30 30 41 50 4F 4E 30 0D '0' '0' 'A' 'P' 'O' 'N' '1' '␣'	Command received (Command echo back)

The data code of CONTRAST and BRIGHTNESS is structured by the difference data of R from G, the main data and the difference data of B from G.

[Example 2] Set the difference data of R from G to +10, the setting main data to 0 and the difference data of B from to -5.

Sending commands from the PC etc.	Status code from projector	Meaning
30 30 50 2B 31 30 2B 30 30 2D 30 35 0D '0' '0' 'P' '+' '1' '0' '+' '0' '0' '-' '0' '5' '␣'		Command for setting the picture control
	30 30 50 2B 31 30 2B 30 30 2D 30 35 0D '0' '0' 'P' '+' '1' '0' '+' '0' '0' '-' '0' '5' '␣'	Command received (Command echo back)

[Example 3] The TINT was set to +10 when the setting status was confirmed.

Sending commands from the PC etc.	Status code from projector	Meaning
30 30 53 0D '0' '0' 'S' '␣'		Command to confirm setting of TINT
	30 30 53 2B 31 30 0D '0' '0' 'S' '+' '1' '0' '␣'	Command (setting of TINT is +10) carried out