



**MITSUBISHI
ELECTRIC**

MULTIMEDIA DATA/VIDEO PROJECTORS

Changes for the Better



Our New Standard... Their New Benchmark...
Engineered for Richer Colors and High Brightness.



Mobile XGA

XD520U



Functional Performance at its best

- ▶ 3000 ANSI lumens of outstanding brightness
- ▶ 2000:1 rich contrast ratio
- ▶ Center lens design for easy symmetrical installation
- ▶ Splash screen and wall screen support
- ▶ Separate audio and video inputs for computers and video sources
- ▶ Time-saving instant shut down feature
- ▶ Closed caption support

Easy Maintenance & Enriched Security Features

- ▶ Top-access lamp cover for easy lamp replacement
- ▶ Filter-free design
- ▶ Enhanced security features with an anti-theft security bar and password protection



Top Access Lamp Cover



Splash screen

BrilliantColor™ Technology and Mitsubishi's Engineering Yields Superior Color Performance

BrilliantColor™ Technology is Texas Instruments' latest innovation for richer colors and better imaging for vibrant displays. At Mitsubishi, we developed a 6-segment color wheel that includes RGBWYC. Apart from the typical red, green, blue and white, we added yellow and cyan segments to display a wider color spectrum. In addition, we coded our color algorithms to emphasize brightness or color modes, designed to match the environment where the XD520U is used.

Together with selective lamp powered modulation techniques, the XD520U with BrilliantColor™ technology acts intelligently to boost colors to improve the intensity and vibrancy of an entire display. For instance, when projecting an already-bright screen image, the lamp is programmed to provide brighter, more vivid colors. In contrast, if the image shows genuine color reproduction, the algorithm delivers just the right colors with the appropriate radiance for maximum visual impact.

*BrilliantColor is a trademark of Texas Instruments.

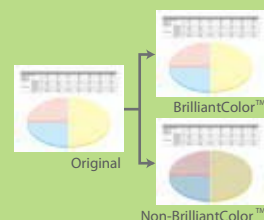
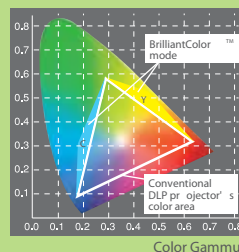



Mobile XGA XD520U

NEW



Input and Output Terminals

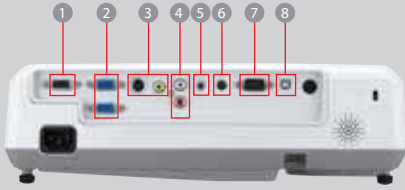

- 1 PC / Component Video output
- 2 PC / Component Video input (mini D-sub 15pin)
- 3 S-Video / RCA
- 4 Audio input [RCA jack (L/R)]
- 5 Audio input (stereo mini jack)
- 6 Audio output
- 7 Serial RS-232C
- 8 USB terminal for Page Up/Down

Specifications

Model	XD520U
Display technology	0.55"1-Chip DMD, 12 Deg, LVDS, DDP 2230
Resolution	1024 x 768 (total 786,432 pixels)
Brightness	3000lm
Contrast	2000:1 (on/off)
Throw Ratio	1.62 - 1.96
Picture Size	40" ~ 300" Diagonal Screen
Source lamp	280W (Shut Off Time 2000Hrs) with Standard Mode 230W (Shut Off Time 3000Hrs) with Low Mode,
Computer compatibility	640 x 480 ~ 1024 x 768, 1280 x 1024 (compressed), Sync on green available
Video compatibility	NTSC / NTSC 4.43 / PAL (including PAL-M, N) / SECAM/PAL-60 Component Video : 480i/p (525i/p), 576i/p (625i/p), 720p (750p), 1080i (1125i 60Hz), 1080i (1125i 50Hz)
Input terminals	RGB : mini D-sub15pin x 2, Video : RCA x 1 + S-video x 1 PC Audio: stereo mini jack (φ35mm) X1, Video Audio: RCA Jack (L/R) x 1
Output terminals	RGB: mini D-sub15pin x 1, Audio : stereo mini jack (φ3.5mm) x 1
Communication terminals	RS - 232C (D-sub 9pin) x 1, USB terminal for Page Up/Down x 1
Audio speaker	2W mono
Dimensions (WxHxD)	332 x 102 x 250 mm / 13.1 x 4.0 x 9.8 inch (excluding height adjustment)
Weight	3.2kg / 7.0lbs
Power supply	AC 100-240V, 50/60Hz
Optional lamp	VLT-XD520LP

*All brand names and product names are trademarks, registered trademarks or trade names of their respective holders.

Dimensions

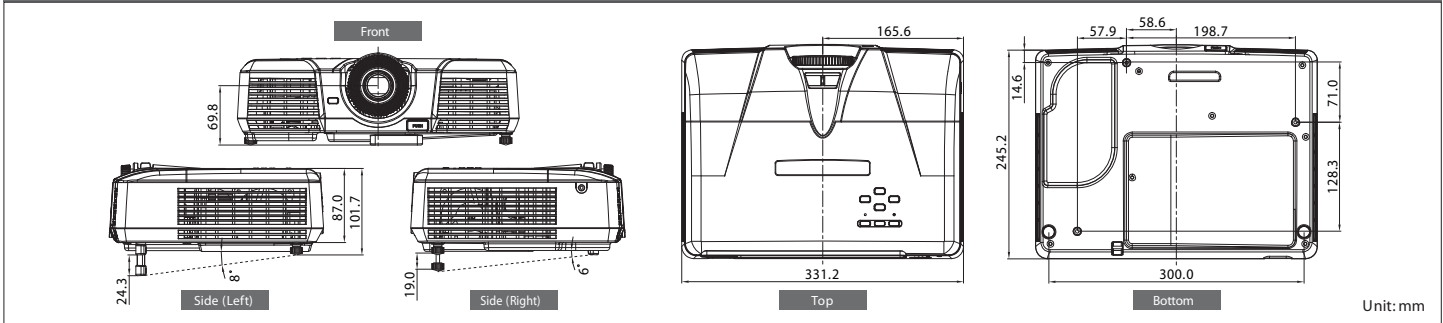

Screen size and Projection distance

As seen from the side

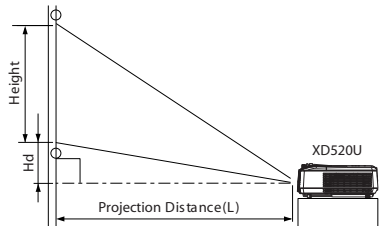

Screen size chart

Screen (4:3 aspect ratio)			Distance from screen (L)		Height projected image (Hd)		Screen (16:9 aspect ratio)			Distance from screen (L)		Height projected image (Hd)											
Diagonal size	Width (W)	Height (H)	Shortest	Longest	Shortest	Longest	Diagonal size	Width (W)	Height (H)	Shortest	Longest	Shortest	Longest										
inch	cm	inch	inch	m	inch	m	inch	cm	inch	cm	inch	m	inch	cm									
40	102	32	81	24	61	51	1.3	62	1.6	1.8	5	40	102	34.9	89	19.6	50	56	14	68	1.7	5.2	13
60	152	48	122	36	91	77	2.0	94	2.4	2.7	7	60	152	52.3	133	29.4	75	84	2.1	102	2.6	7.9	20
80	203	64	163	48	122	103	2.6	125	3.2	3.6	9	80	203	69.7	177	39.2	100	113	2.9	137	3.5	10.5	27
100	254	80	203	60	152	129	3.3	157	4.0	4.5	11	100	254	87.2	221	49.0	125	141	3.6	171	4.4	13.1	33
150	381	120	305	90	229	195	4.9	236	6.0	6.8	17	150	381	130.7	332	73.5	187	213	5.4	258	6.5	19.6	50
200	508	160	406	120	305	260	6.6	315	8.0	9.0	23	200	508	174.3	443	98.1	249	284	7.2	344	8.7	26.2	66
250	635	200	508	150	381	326	8.3	394	10.0	11.3	29	250	635	217.9	553	122.6	311	356	9.0	430	10.9	32.7	83
300	762	240	610	180	457	391	9.9	-	-	13.5	34	300	762	261.5	664	147.1	374	427	10.8	-	-	39.3	100

The above numbers are approximate, and may be slightly different from the actual measurements.

MITSUBISHI DIGITAL ELECTRONICS
AMERICA, INC.
Presentation Products Division
Phone: 888.307.0349
Email: ppdinfo@mdea.com
www.mitsubishi-presentations.com

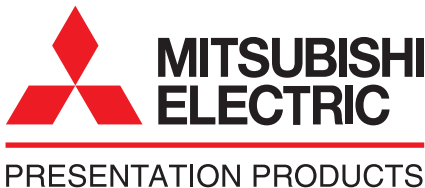

MITSUBISHI ELECTRIC SALES
CANADA INC.
Information Technologies Group
Phone: 905.475.7728
www.mitsubishielectric.ca